

Series E14 Hub Shaft

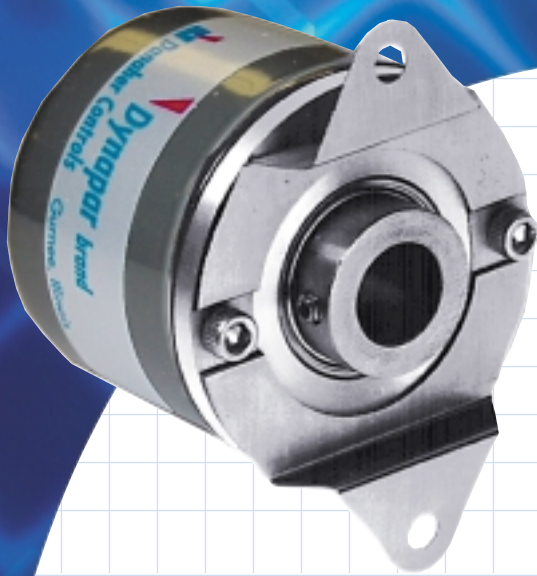

- **Easy installation on motor or machine shafts**
- **Large and small hub availability**

The Dynapar brand Series E14 Hub Shaft encoder is designed for easy installation on motor or machine shafts. Its hub shaft design and flexible spring mount eliminate the need for a mounting flange adapter and flexible coupling. This not only reduces the encoder's depth, but also lowers installation cost.

The Series E14 Hub Shaft includes precision bearings, an O-ring seal, and a selection of bore sizes ranging from 6 mm to 5/8".

Series E14 incorporates the latest in micro-electronic packaging, LED light sources, and matched sensors. Outputs are designed to be compatible with most 5V TTL circuits with options for higher voltage 12 and 15 VDC. Shielded cable is standard. A 5V line driver with complementary outputs is available for longer cable runs and higher electrical noise immunity.

Mechanical and Environmental Features

- Durable metal housing
- O-ring housing seal
- Hub sizes ranging from 6 mm to 5/8"
- Up to 5000 RPM
- NEMA 12 / IP56

Electrical Features

- Up to 2540 pulses per revolution, optional marker pulse
- Operating speed up to 100 kHz
- LED light source and matched sensors
- Choice of 5, 12, or 15 VDC power
- Shielded cable and line driver available for higher electrical noise immunity

SPECIFICATIONS

Electrical

Code: Incremental

Resolution: 100 to 2540 PPR (pulses/revolution)

Format: Two channel quadrature (AB) with optional Index (Z) outputs

Phase Sense: A leads B for CW shaft rotation as viewed from the shaft end of the encoder

Accuracy: $\pm 3 \times (360^\circ \div \text{PPR})$ or ± 2.5 arc-min worst case pulse to any other pulse, whichever is less

Quadrature Phasing: $90^\circ \pm 36^\circ$ electrical

Symmetry: $180^\circ \pm 18^\circ$ electrical

Index: $90^\circ \pm 25^\circ$ (gated with A and B high)

Waveforms: Squarewave with rise and fall times less than 1 microsecond into a load capacitance of 1000 pf

Input Power:

5 VDC $\pm 5\%$ at 80 mA max.;
12 or 15 VDC $\pm 10\%$ at 80 mA max.; not including output loads

Outputs:

7272 line driver, 40 mA sink and source

Frequency Response: 100 kHz min.

Mechanical

Bearing Life: $(16 \times 10^6 \div \text{RPM})$ hours at max. load

Shaft Speed: 5,000 RPM max.

Hub Dia. Tolerance: nominal $-0/+0.0005"$ (0.013mm)

Mating Shaft Length: 0.25" (6 mm) min.; 0.50" (12 mm) max.

Mating Shaft Runout: 0.008" (0.2 mm) max. TIR

Mating Shaft Endplay: $\pm 0.010"$ (0.25 mm) max.

Starting Torque: 0.9 oz-in max. at 25 °C

Running Torque: 0.8 oz-in max. at 25 °C

Moment of Inertia:

6 to 10 mm hub: 6.03×10^{-5} oz-in-sec²

12 mm to 5/8" hub: 2.4×10^{-4} oz-in-sec²

Weight:

6 to 10 mm hub: 3.5 oz. max.

12 mm to 5/8" hub: 4.5 oz. max.

Environmental

Operating Temperature: 0 to +70 °C

Storage Temperature: -25 to +70 °C

Humidity: to 98% without condensation

Enclosure Rating: NEMA12/IP54 (dirt tight, splashproof) Optional: NEMA 3/IP64 rating available (consult factory)

Code 4: Mechanical

D - H, N: 1/4" to 10 mm

J - M: 12 mm to 5/8"

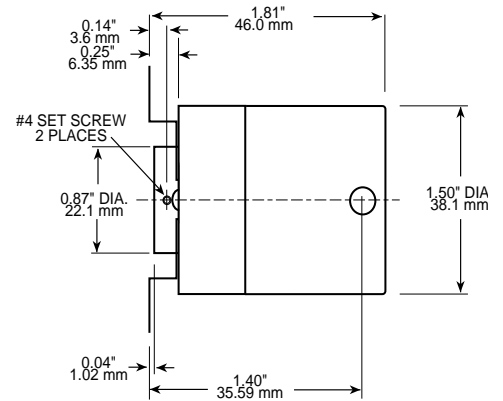
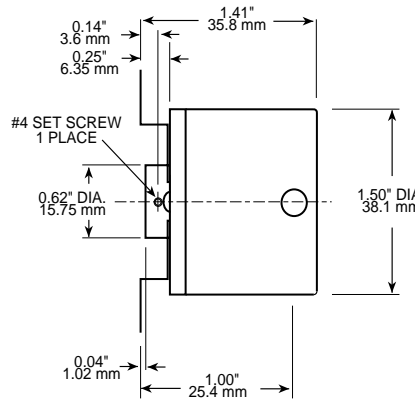
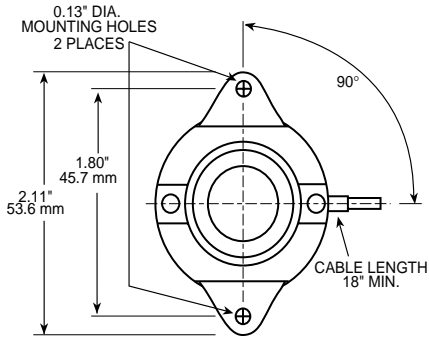

Electrical Connections

Wire Color Code	Function		
	Single-Ended Outputs	Differential Outputs	
		Unidirectional	Bidirectional
Red	Power Source	Power Source	Power Source
Black	Common	Common	Common
White	Signal A	Signal A	Signal A
Green	Signal B (if used)	Signal \bar{A}	Signal B
Orange	Signal Z (if used)	No Connection	Signal \bar{B}
Blue	No Connection	No Connection	Signal \bar{A}
Shield	Floating	Floating	Floating
White/Black	—	—	Signal Z (if used)
Red/Black	—	—	Signal \bar{Z} (if used)

Ordering Information

To order, complete the model number with code numbers from the table below:

Code 1: Model	Code 2: Pulses/Rev	Code 3: Mounting	Code 4: Mechanical	Code 5: Output	Code 6: Electrical	Code 7: Termination
E14	<input type="checkbox"/> <input type="checkbox"/> <input type="checkbox"/> <input type="checkbox"/>	<input type="checkbox"/>	<input type="checkbox"/>	<input type="checkbox"/>	<input type="checkbox"/>	<input type="checkbox"/>
E14 Size 14, Hub Shaft	0100 1000 0200 1024 0240 1250 0250 1500 0256 2000 0300 2048 0360 2500 0400 2540 0500 0600 0720 0750 0900	0 Size E14	Hub I.D. D 6 mm E 1/4" F 5/16" G 3/8" H 10 mm J 12 mm K 1/2" L 14 mm M 5/8" N 8 mm	0 Single Ended, Unidirectional 2 Single Ended, Bidirectional, no Index 3 Single Ended, Bidirectional, with Index 4 Differential, Unidirectional 6 Differential, Bidirectional, no Index 7 Differential, Bidirectional, with Index	0 5 VDC 1 12 VDC 2 15 VDC	0 18" Cable 1 3' Cable 2 6' Cable 3 10' Cable 4 15' Cable